

# 18. Water testing

The objective of bacteriological testing of water is to detect and determine the concentration of faecal bacteria in water supplies in order to:

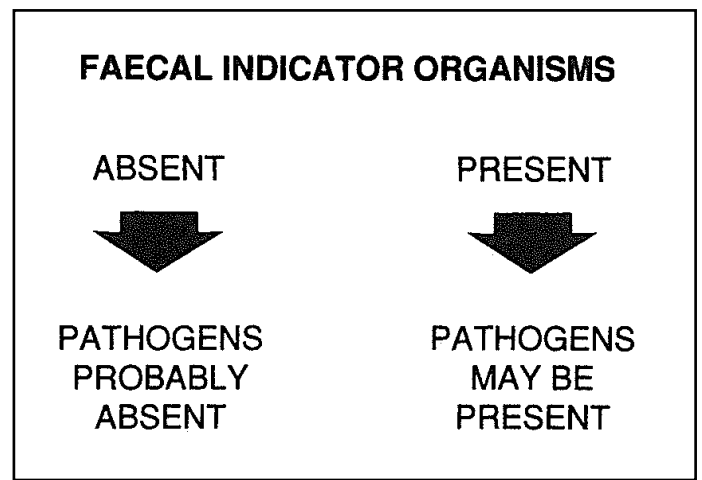

Diagram A

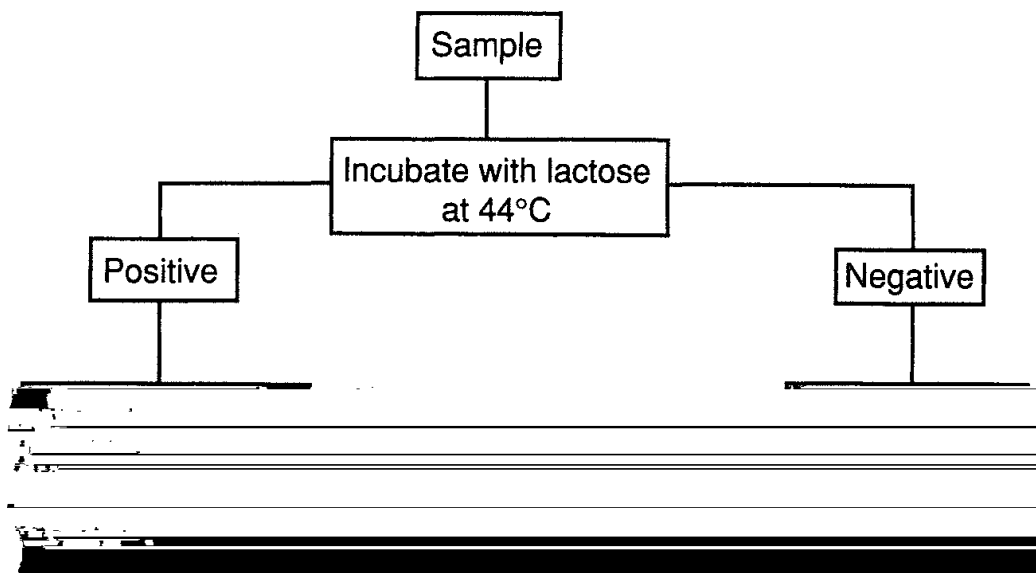

Diagram B



## b) Most probable number (MPN) multiple-tube method

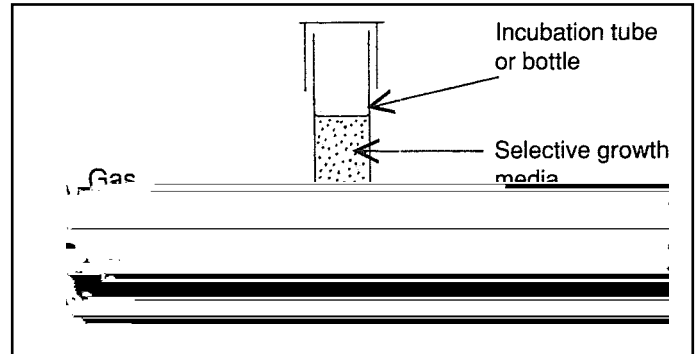

Diagram D

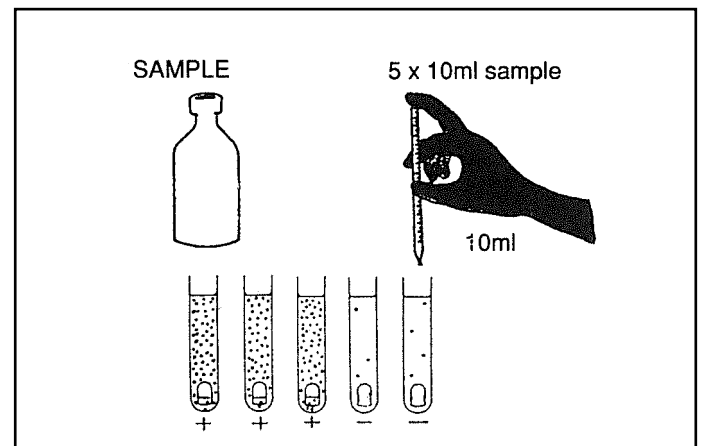

Diagram E

## Incubators

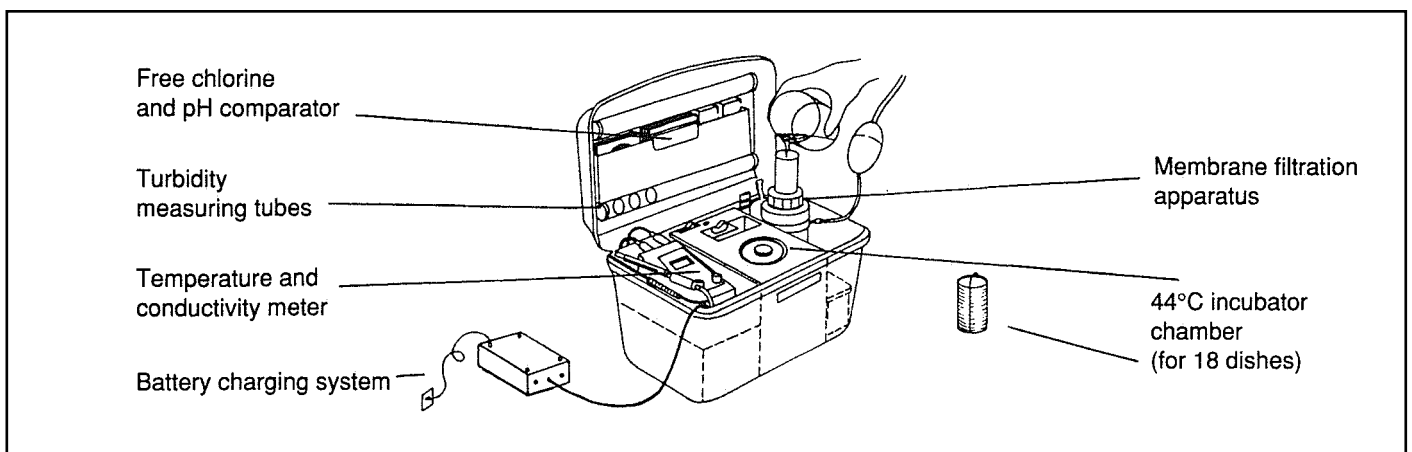

Diagram F

## Autoclaves

## Membrane filtration apparatus

## General hygiene and cleanliness

## Samples

*B* 0.

## References and further reading

/ / , *E* ,1 , , ,  
 ,1 0.  
 , , , , , ,1 .  
 , *B* *E* *D* , , ,1 2.  
 , , *F* *D* *C* , , ,1 .  
 1 . , , *F* . , , .01 0, ,  
 , *D* , V . , , ,1 .